



STRETCH WRAPPER  
MODEL: CSA TWIN

# CSA Twin Unique

Compact, high performance rotating arm machine (patented) with double reels for wrapping pallets with stretch film. Reliable and robust construction.

## Technical Characteristics

Conveyor height	500 mm
Maximum rotation speed	30 rpm
Protection on electric system & motors	IP 54
Total power installed - 2HD	4,5 Kw – 5,5 Kw with Top
Standard power supply	400V – 50 Hz – 3 PH+N+G
Operating pressure	6 bar
Max rotation speed	28 rpm
Production capacity per h	Up to 95

## Product Dimensions

Max pallet dimensions	1100 x 1300 mm
Min pallet dimensions	600 x 600 mm
STD pallet height	2100 mm
Wrapping capacity pallets/h	95 pallet/h

## Save your Money



Motorized pre-stretch system with 3 driven rollers electronically controlled with interchangeable ratios: 150 - 200 - 250%.

- Optionals
- Acid protection.
  - For loads up to 3300 mm high.
  - Pallet holder presser.
  - Corner applicator.
  - Clamp cut and tuck for threading the stretch film tide inside the wrap.
  - Roping system.
  - Top cover.
  - Pallet lifter.
  - Extended arm for bigger loads.

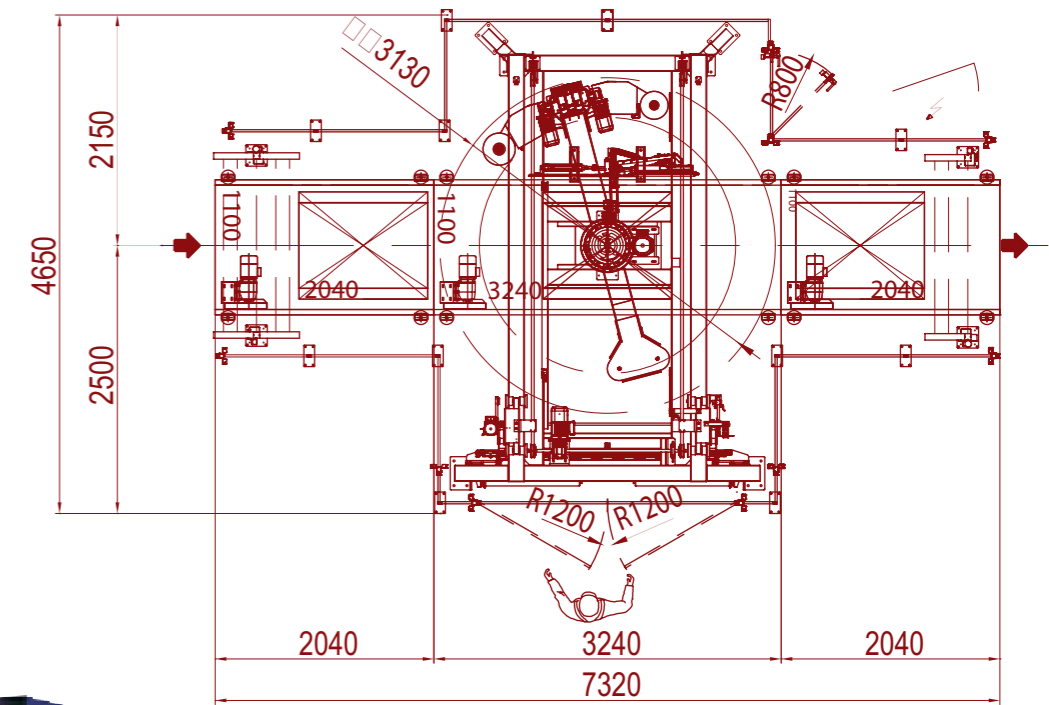

Patented system



Control panel equipped in a standard version with a touch-screen operator Display.

95 pallet per hour

WWW.CYKLOP.NL  
+31 384675800

CYKLOP Nederland BV  
Benjamin Franklinstraat 5  
8013 NC Zwolle  
info@cyklop.nl

